

TFV

TEHN  **FILTER**
air purification solutions

Table of contents

1. GENERAL INFORMATION.....	4
1.1. Copyright	4
1.2. Norms and regulations	4
1.3. Limitation of liability	4
2. SAFETY	5
2.1. Warning instructions	5
2.1.1. Explanation of symbols	6
2.2 Intended use	7
2.3. Foreseeable misuse	7
2.4. Obligation of the operator	7
2.5. Selection and qualification of the personnel.....	8
2.6. Basic safety instructions	8
2.6.1. Electrical hazards	9
2.6.2. Mechanical hazards.....	9
2.6.3. Hazard due the noise	10
2.6.4. Hazard due to the exhausted media	11
3. DESCRIPTION.....	12
3.1. Marking.....	12
3.1.1. Identification plate.....	13
3.1.3. Legibility of the identification plate.....	13
3.1.4. Identification plate location	13
3.2. Basic parts of the unit	14
3.3. Functional principle.....	15
4. TECHNICAL DATA	16
4.1. Ambient conditions	16
4.2. Noise emissions	16
4.3. Dimensions.....	16
4.4. Exhaust capacity	17
4.5. Filtering surface	17
4.6. Dust collection bin	17
4.7. Weight	17
4.8. Electric connection values	18
4.9. Pneumatic connection values.....	18
5. TRANSPORT AND INSTALLATION.....	20

5.1. Requirement for the installation.....	20
5.2. Unpacking.....	20
5.3. Transporting the device.....	21
5.4. Installation.....	22
6. START UP.....	23
6.1. Comissioning.....	23
6.2. Instructions for the first start up.....	25
6.2.1. Entrust pressure gauge.....	25
6.2.2. Position of exhaust hood.....	26
6.2.3. Timer mode parameters.....	27
7. MALFUNCTIONS.....	28
7.1. Faults overview.....	28
7.1.1. Product.....	28
8. MAINTENANCE AND REPAIR.....	29
8.1. Maintenance schedule.....	29
8.1.1. Visual inspection.....	30
8.1.2. Functional check.....	30
8.1.3. Check the filter elements.....	31
8.1.4. Emptying the compressed air tank.....	31
8.1.5. Replacing filter cartridges.....	32
8.1.6. Emptying dust collection bin.....	33
9. DECOMMISSIONING.....	34
9.1. Prepare for storage.....	34
9.2. Storage conditions.....	35
9.3. Disposal.....	35
10. SPARE PARTS.....	36

1. GENERAL INFORMATION

1.1. Copyright

Copyright © Tehno Filter Ltd. 2021. This document is copyright protected. Reprinting, duplication, translation, or other use, even in sections, is not permitted without authorization of Tehno Filter Ltd. Tehno Filter d.o.o. explicitly retains all rights pursuant to copyright law. Tehno Filter Ltd. reserves the right to claim damages in the event of infringement of this copyright. We reserve the right to further claims.

1.2. Norms and regulations

Generally valid and legal regulations and other binding rules regarding accident prevention and environmental protection are not separately detailed here, but must be strictly observed nonetheless.

1.3. Limitation of liability

All the technical information, data, and instructions contained in this operating manual regarding usage and maintenance of the device are current upon delivery. The manual reflects the knowledge gained from Tehno Filter Ltd's past experience to the best of our ability. Tehno Filter Ltd. reserves the right to make technical changes in the course of the further development of the device described in this operating manual. Hence no claims whatsoever can be derived from the information, illustrations, and descriptions contained in this operating manual.

Tehno Filter Ltd. Assumes no liability for operating malfunction or damage caused by:





- user error
- disregard of the operating manual
- faulty repairs
- the use of spare parts which are not supplied, checked or approved by Tehno Filter Ltd.
- software programs, such as antivirus software, that were not approved for the control and other components
- Reconstruction or modification which was not approved
- installation or use of third – party products which was not approved

While excluding further claims, the Tehno Filter Ltd. is liable for any errors or omissions in the warranty obligations stipulated in the contract. Compensation claims are excluded regardless of the legal grounds on which they are based. Translations of the original operating manual are carried out to the best of our knowledge. Tehno Filter Ltd. assumes no liability for translation errors. The written and graphic descriptions in this operating manual do not necessarily correspond with the scope of delivery or a spare part order.

The illustrations and figures are not always shown in a scale of 1:1.

2. SAFETY









2.1. Warning instructions

	<p>DANGER ! HIGH RISK IF THERE IS A SERIOUS DANGER LEVEL</p> <p><i>Indicate an imminent danger. If not averted, death or severe injuries will result.</i></p>
	<p>WARNING ! MEDIUM RISK IF THERE IS A SERIOUS DANGER LEVEL</p> <p><i>Indicate a potential threat. If not avoided, death or severe injuries may result.</i></p>
	<p>CAUTION ! RISK WITH MINOR DANGER LEVEL</p> <p><i>Indicate a potential threat. If not averted, slight or minor injuries may result.</i></p>
	<p>NOTICE ! PROPERTY DAMAGE</p> <p><i>Foreseeable material damage for the product and environment with a failure to comply with the specified measures.</i></p>

This warning is displayed when there is a threat of danger or damage. This represents actions which can cause a risk of damage.

Warnings are indicated with a symbol or signal word. The warning includes information on the type and source of the hazard, the consequences if it occurs, and actions to take to avert it.

2.1.1. Explanation of symbols

Warning notices		General warning signs		Electric voltage
		Hearing damage		Toxic dusts
		Danger of crushing Hand injuries		Falling/tipping hazard
				
		Suspended load		Automatic startup

Prohibition symbols		General prohibition		Read the manual
		Wear ear protection		Wear safety goggles
		Wear safety footwear		Use head protection
		Wear gloves		Use breathing protection
		Wear protective clothing		Enable before maintenance or repair work

2.2 Intended use

The device is intended for cleaning the air in welding process. The device may be used only according to the following instructions. In the case of extracting welding fumes containing carcinogenic levels such as are created when welding alloy steels (eg: stainless steel), according to official regulations, only devices tested and approved for the so-called recirculated air method may be used. This filter unit is approved for extracting welding fumes emitted during welding of steels with an alloy content of 30% and complies with the requirements for the welding fume separation class W3, according to DIN EN ISO 15012-1. Any utilization or operation that goes beyond the scope of these tasks is deemed unintended, and can lead to serious personal injury or major damage.

Dimensions and further details can about TFV filter units must be observed in section 4. Technical data.

2.3. Foreseeable misuse

The device may not to be used for exhausting or cleaning any other media. Without appropriate upgrading of the filtration system, neither dusts that are adhesive or heavily fibrous or contain moisture or large quantities of oil nor, in particular, smoke may be aspirated.

2.4. Obligation of the operator

The operator is responsible for safe operation and proper usage. The operator must ensure that:

- The personnel have been informed on the dangers associated with work with the device
- The personnel are qualified and receive the necessary technical training
- The personnel have read and understood the operating manual
- The personnel have access to the operating manual at all times
- The device is operating only if it is in perfect working condition
- No changes are made to the device that would reduce the safety
- Damage to the device is repaired promptly
- Maintenance work is carried out regularly

2.5. Selection and qualification of the personnel

This operating manual was written for authorized and trained personnel who are permitted to set up, maintain, repair, and operate the device. Personnel are divided into four groups:

	The following task may be carried out only by persons that have at least the qualification of the operating personnel.		The following task may be carried out only by persons that have at least the qualification of the setup personnel.
	The following task may be carried out only by persons that have at least the qualification of the maintenance and repair personnel.		The following task may be carried out only by persons that have at least the qualification of the transport personnel.

2.6. Basic safety instructions

Even though the device has been constructed for safety, some potential hazards always remain during operation. In the following, the main dangers and risks are listed that can occur during operation of the device. To avoid operating malfunctions and injuries, the safety instructions must be observed closely. The following list is not complete as further dangers and risks may arise due to individual operational conditions.

2.6.1. Electrical hazards

	DANGER !
	<p>ELECTRIC SHOCK FROM HIGH VOLTAGES <i>Severe injury and even death possible</i></p> <ul style="list-style-type: none">• Any work on the electrical grid and on live components may be performed by an electrician• Follow the safety rules for working on electrical products• Shut down the product or any live components before working on them and secure them against reactivation• Establish electrical connection of the components according to the manufacturer's specifications• Protect the power supply cables against damage and dimension them according to the power uptake of the drive motor• Perform the electrical installation and connection in compliance with applicable federal, state and local regulations and legal standards• Regularly check the power cable for damage and wear• Do not switch on the product if there is visible or otherwise identified damage on the product, its power supply or other components• Do not clean electrical components with a water jet• Check the protective devices (motor protection relay, ground resistor etc.) and set them to the operating condition of the product

2.6.2. Mechanical hazards

	WARNING !
	<p>CRUSHING HAZARD DUE TO LOOSE OR OPEN COVERS <i>Injuries to the limbs</i></p> <ul style="list-style-type: none">• Keep covers tightly closed during operation• Ensure that inspection doors if available are firmly closed• Check regularly that fastening screws and component connections are secure• Only start up the product after the assembly is complete and correct

	<p>DANGER !</p> <p>DANGER OF FALLING AND TIPPING <i>Risk of fatal injury due to falling components or loads</i></p> <ul style="list-style-type: none"> • do not stand under suspended loads • secure the assembly area and mark it out (e.g., with barrier tape) • secure the danger area sufficiently against unauthorized access during loading and setup work • always lift the product vertically during loading and assembly work • suitable, approved hosting and transportation equipment may only be attached to the transport lugs • keep a sufficient distance from the product while it is being installed • wear personal protective equipment • use industrial truck with a lift capacity of at least min. the device weight • lift the device only on holes intended for use
---	--

2.6.3. Hazard due the noise

During normal operation, the noise emission is < 75 db(A). The noise emission can increase if installation is incorrect or if fan is defective. During the cleaning cycle, noise emission can be > 75 db (A). Noise can lead to persons becoming less attentive. Furthermore, noise can interfere with communication of the personnel.

	<p>CAUTION !</p> <p>RELEASE OF COMPRESSED AIR PULSES WHEN FILTER ELEMENTS ARE BEING CLEANED <i>Risk of hearing damage</i></p> <ul style="list-style-type: none"> • Wear personal protective equipment • Do not open the product during cleaning • Ensure that inspection doors are firmly closed • Disconnect the compressed air supply from the product • Empty the compressed air tank
---	--

2.6.4. Hazard due to the exhausted media

If exhausted media is swallowed, inhaled or improperly handled, allergies and irritation can be triggered by the exhausted media or their vapors.

	CAUTION !
	TOXIC DUSTS <i>Short-term impairment of the respiratory organs during inhalation</i> <ul style="list-style-type: none">• Maintenance, cleaning, repair and emptying work may only be performed by expert personnel• Wear personal protective equipment• Regularly check the filter elements for clogging• Always complete all maintenance and upkeep work in a well-ventilated area• Do not blow out or whack the filter elements when they are disassembled• Dispose of used filter elements in air tight sealed disposal bags in accordance with applicable federal, state and regional regulations

3. DESCRIPTION

TFV filter units are intended for exhaust fumes of Class 3, formed by welding of (non-alloy steel and high alloy steel with nickel and chrome content with share of >30%). Gases are not separated by filtration. TFV is not intended for outdoor use. Always keep the unit in a dry environment. Intended for use with extraction arms connected to the inlet. Full rotatable 270° flexible extraction arm gives us efficient extraction of the harmful gases and particles. Equipped with pulse jet cleaning system for better cleaning of the filter cartridges.

3.1. Marking

This manual refers to the cartridge filter unit series as a “device”. Device designation TFK – V reflects its design:

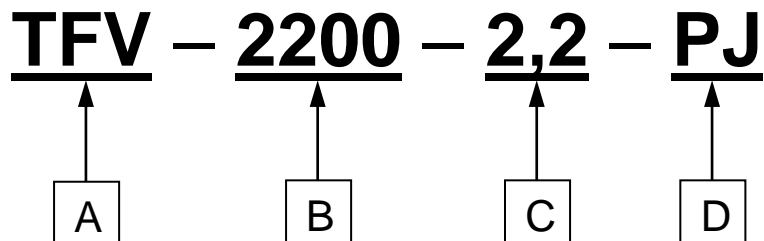

A) Type of the unit – filter unit for wall installation with vertical cartridges

B) Size of the unit as follows: 1100, 2200 ...

- represent the maximum airflow capacity in m³/h

C) Installed power in kW

D) Type of cleaning:

- PJ: pulse jet cleaning system

- Without mark – manual cleaning

3.1.1. Identification plate

TEHN FILTER		EAC CE	
air purification solutions			
Model / Type: Model/Tip:	TFV-1100	Serial Number: Numer seryjny:	380-22-1
Air flow/Protok zraka: Max. wydajność filtra:	1500 m3/h	Year: Rok :	2022
Connection voltage: Napięcie:	400V/50Hz	Compres. air min: Sprężone powietrze min:	4 bar
Rated current: Prąd znamionowy:	3,1 A	max.: max.:	5 bar
Motor power: Moc silnika:	1,1 kW	Weight [kg] : Waga (kg):	180
Current Type : Sposób zasilania:	3 ~+N+PE		
Tehno Filter d.o.o., Valpovačka 24, 31300 Beli Manastir, Croatia, info@teho-filter.hr			

3.1.3. Legibility of the identification plate

The ID plate must be kept in perfect condition by cleaning it periodically so that the data are perfectly legible. If the ID plate is damaged and/or is no longer legible as regards even just one of the information elements shown then, contact the Manufacturer for a copy and replace the old one.

3.1.4. Identification plate location

The identification plate is made of aluminium adhesive material, dimension approx. 10 x 7cm and its location is marked with a red square on the illustration below.

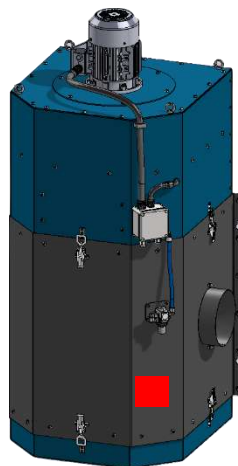

3.2. Basic parts of the unit

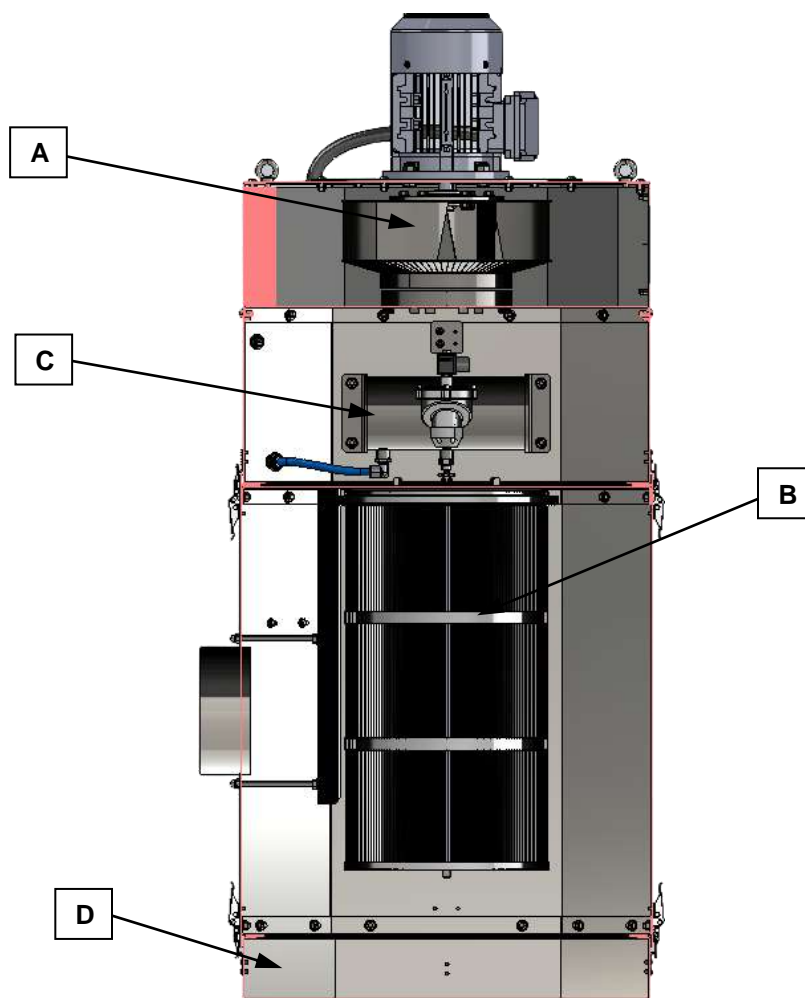

A	Centrifugal fan
B	Filter cartridge
C	Compressed air tank with cleaning nozzles
D	Dust collection bin

3.3. Functional principle

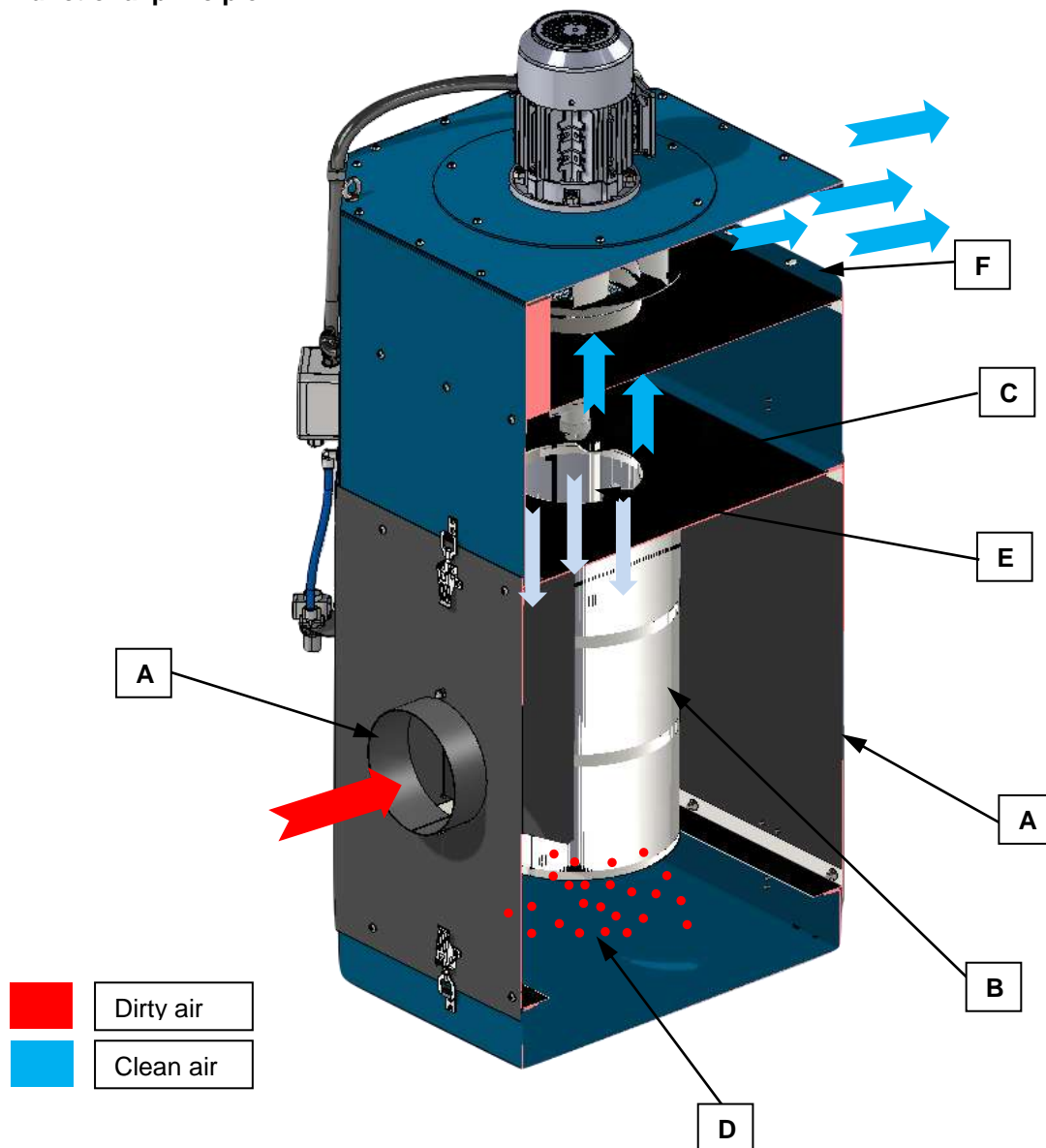

1. Air enters through the inlet opening from the left or right inlet flange [A].
2. Fine dust accumulate on the outside of the filter cartridge [B].
3. Cleaned air passing through the clean chamber over the centrifugal fan [C].
4. Fine dust falling into dust collection bin – small [D] after pulse jet cleaning [E].
5. Clean air enter the working area [F]

4. TECHNICAL DATA

4.1. Ambient conditions

Ambient conditions	
Temperature	5-40°C
Relative humidity	0-70%
Vibration	None

4.2. Noise emissions

During normal operation noise emission is at < 75 db (A). The noise emission increase if installation is incorrect or if the centrifugal fan is defective. During the cleaning cycle, noise emission briefly reach > 75 db (A).

4.3. Dimensions

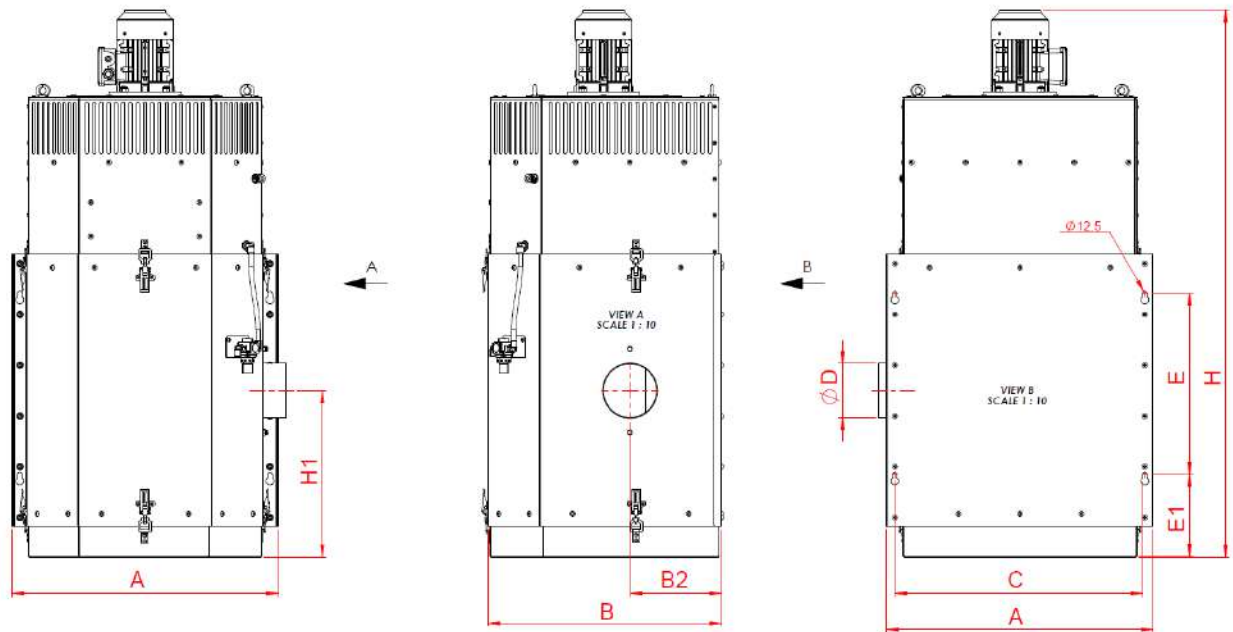

Model	A	B	B2	C	ØD	E	E1	H	H1
TFV - 1100	737	645	253	685	150	500	228	1510	459,5
TFV - 1500	737	645	253	685	150	500	228	1560	459,5
TFV - 2200	737	645	253	685	2 x 150	500	228	1560	459,5

General dimensions for standard execution models. For models on special request please refer per approval drawing.

Note: All dimensions in mm.

4.4. Exhaust capacity

<i>Exhaust capacity</i>		
Model	Max. Airflow Capacity [m³/h]	Max. Pressure [Pa]
TFV - 1100	1100	1800
TFV - 1500	1500	1770
TFV - 2200	2200	1840

4.5. Filtering surface

<i>Filtering surfaces</i>			
Model	Number of cartridges	Filter surface [m²]	Total filter surface [m²]
TFV - 1100	1	10	10
TFV - 1500			
TFV - 2200			

4.6. Dust collection bin

<i>Dust collection bins</i>	
Model	Total volume [L]
TFV - 1100	40
TFV - 1500	
TFV - 2200	

4.7. Weight

<i>Weight</i>	
Model	Weight [kg]
TFV - 1100	180
TFV - 1500	190
TFV - 2200	200

4.8. Electric connection values

<i>Electric connection values</i>			
Model	Motor power [kW]	Voltage [V]	Frequency [Hz]
TFV – 1100	1,1	400	50
TFV – 1500	1,5		
TFV - 2200	2,2		

4.9. Pneumatic connection values



NOTICE !

Compressed air for filter unit must be supplied by a separate line that can be disconnected independently.

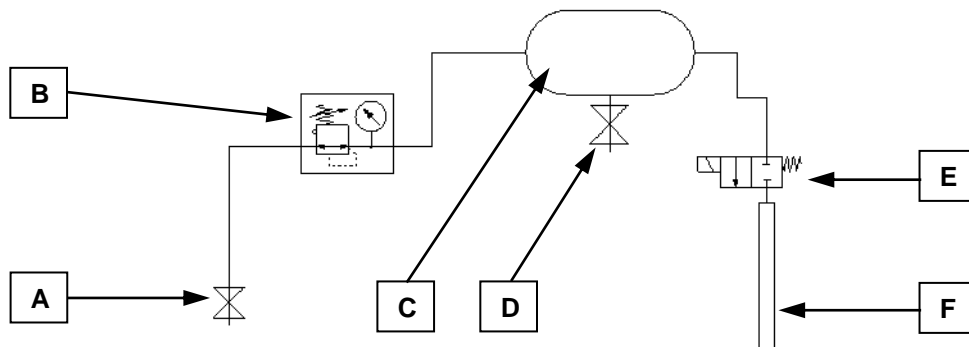

<i>Connection diagram</i>	
Position	Description
A	Manual ball valve (Not supplied by Tehno Filter Ltd.)
B	Filter regulator with gauge
C	Compressed air tank
D	Condensate drain valve
E	Solenoid valve
F	Blowing pipe with nozzle

<i>Compressed air values</i>				
Size	Max pressure [bar]	Connection [DN]	Consumption [l/h]	Quality
all	6	12	3600	Dry and oil free

Compressed air consumption values are for default settings: 60s cleaning cycle at 100ms opening time.

	NOTICE !
	<p>RISK OF CORROSION OF THE COMPRESSED AIR TANK OR DAMAGE TO THE FILTER ELEMENTS WHEN USING UNFILTERED COMPRESSED AIR</p> <p>Use a compressed air maintenance unit to make sure that only oil-free and water-free compressed air is fed into the product</p>

5. TRANSPORT AND INSTALLATION

5.1. Requirement for the installation

A suitable installation site needs to fulfill the following requirements:

- Ambient conditions are maintained
- Safety distances are maintained according to the local safety regulations
- The load bearing capacity of the installation site or the bearing construction is sufficient
- When installing on the load bearing construction, this must be designed so that the loads and mass forces are safely supported by the load bearing construction
- A power outlet with an earth conductor is available

5.2. Unpacking

	The following task may be carried out only by persons that have at least the qualification of the transport personnel.
---	--

The product is sometimes delivered fastened to a pallet. After protective covers and the floor fixing have been removed, the device can be lifted and transported using suitable lifting equipment.

- remove the packaging and check the product for damage and completeness
- the product must not be put into operation if there is damage, or if the delivery is incomplete. Contact Tehno Filter Ltd. In such cases
- Any foreign objects inside the product must be removed before startup

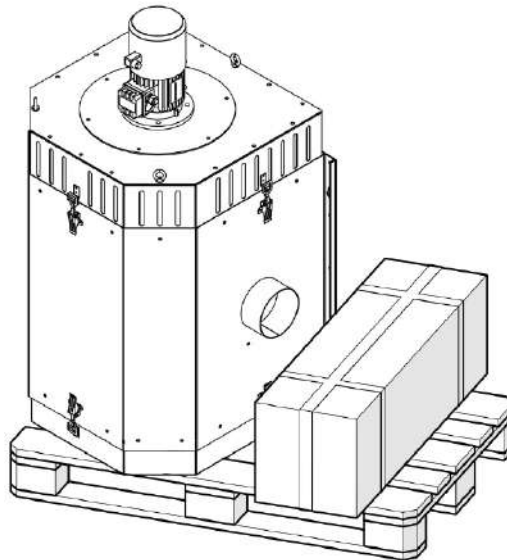

5.3. Transporting the device



The following task may be carried out only by persons that have at least the qualification of the transport personnel.

	DANGER !
	DANGER OF FALLING AND TIPPING <i>Risk of fatal injury due to falling components or loads</i>
	<ul style="list-style-type: none">• do not stand under suspended loads• secure the assembly area and mark it out (e.g., with barrier tape)• secure the danger area sufficiently against unauthorized access during loading and setup work• always lift the product vertically during loading and assembly work• suitable, approved hosting and transportation equipment may only be attached to the transport lugs• keep a sufficient distance from the product while it is being installed• wear personal protective equipment• use industrial truck with a lift capacity of at least min. the device weight• lift the device only on holes intended for use

	WARNING !
	CRUSHING HAZARD WHEN SETTING THE PRODUCT DOWN <i>Injuries to the hands and feet</i>

- secure the products against tipping and falling during transport
- set the product down carefully and cautiously during setup
- wear work gloves and safety shoes

	NOTICE !
	MATERIAL DAMAGE DUE TO IMPROPER TRANSPORT <i>Damage to the housing, lines and product components</i>

- do not push or pull the product across the floor if it does not have any castors
- pay attention to any protruding components when setting down the product
- note that the center of the gravity is not in the middle of the unit when setting down the product
- when loading by crane, the weight, center of gravity and permissible suspension angle (60°) of the lifting load must be taken into account
- make sure that the surface can be driven on, is level and sufficiently load bearing

5.4. Installation



The following task may be carried out only by persons that have at least the qualification of the setup personnel.

When duct installation has been made it's important to follow the guidelines regarding the proper installation:

- straight length of duct entering the inlet transition should be minimum of 2 duct diameters
- avoid bends on inlet much as possible
- during installation always consider the required minimum distances from the product to ceilings and walls

Clearance:

Operating side, front [mm]	1500
Right [mm]	1000
Left [mm]	1000
Top [mm]	1000

6. START UP

6.1. Commissioning



The following task may be carried out only by persons that have at least the qualification of the setup personnel.



DANGER !

ELECTRIC SHOCK FROM HIGH VOLTAGES

Severe injury and even death possible

- Any work on the electrical grid and on live components may be performed by an electrician
- Follow the safety rules for working on electrical products
- Shut down the product or any live components before working on them and secure them against reactivation
- Establish electrical connection of the components according to the manufacturer's specifications
- Protect the power supply cables against damage and dimension them according to the power uptake of the drive motor
- Perform the electrical installation and connection in compliance with applicable federal, state and local regulations and legal standards
- Regularly check the power cable for damage and wear
- Do not switch on the product if there is visible or otherwise identified damage on the product, its power supply or other components
- Do not clean electrical components with a water jet
- Check the protective devices (motor protection relay, ground resistor etc.) and set them to the operating condition of the product





WARNING !

CRUSHING HAZARD DUE TO LOOSE OR OPEN COVERS

Injuries to the limbs

- Keep covers tightly closed during operation
- Ensure that inspection doors if available are firmly closed
- Check regularly that fastening screws and component connections are secure
- Only start up the product after the assembly is complete and correct

	CAUTION !
	<p>DANGER OF INJURY DUE TO FAN IMPELLER START UP <i>Danger of crushing limbs</i></p> <ul style="list-style-type: none"> • Only work on the drive motor / fan impeller when the system is switched off • Shut down the product or any live components before working on them and secure them against reactivation

	CAUTION !
	<p>RELEASE OF COMPRESSED AIR PULSES WHEN FILTER ELEMENTS ARE BEING CLEANED <i>Risk of hearing damage</i></p> <ul style="list-style-type: none"> • Wear personal protective equipment • Do not open the product during cleaning • Ensure that inspection doors are firmly closed • Disconnect the compressed air supply from the product • Empty the compressed air tank

	NOTICE !
	<p>AVOID PROPERTY DAMAGE CAUSED BY ELECTROSTATIC CHARGE</p> <p>Conductive extraction and collection devices and conductive processing machines that are not grounded through the product must be grounded on site by the operating company and must be integrated in the building's equipotential bonding.</p>

	NOTICE !
	<p>PROPERTY DAMAGE</p> <ul style="list-style-type: none"> • Inspect the product before each use for faulty, damaged or missing components • If there is damage, do not use the product and immediately notify the responsible repair personnel

6.2. Instructions for the first start up



The following task may be carried out only by persons that have at least the qualification of the setup personnel.

6.2.1. Entrust pressure gauge

In order to start the device for the first time make sure certain pressure parameter is set.



Compressed air values				
Size	Max pressure [bar]	Max pressure [MPa]	Connection [DN]	Quality
All	6	0,6	12	Dry and oil free

6.2.2. Position of exhaust hood

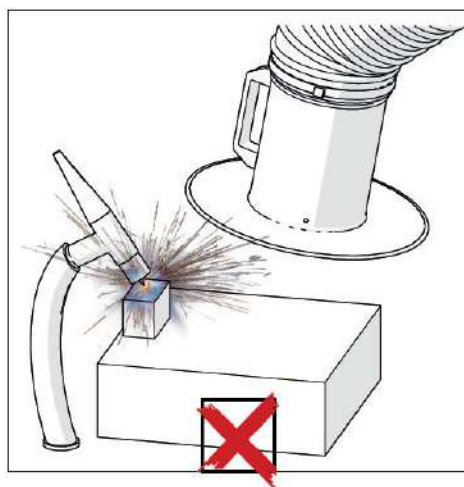
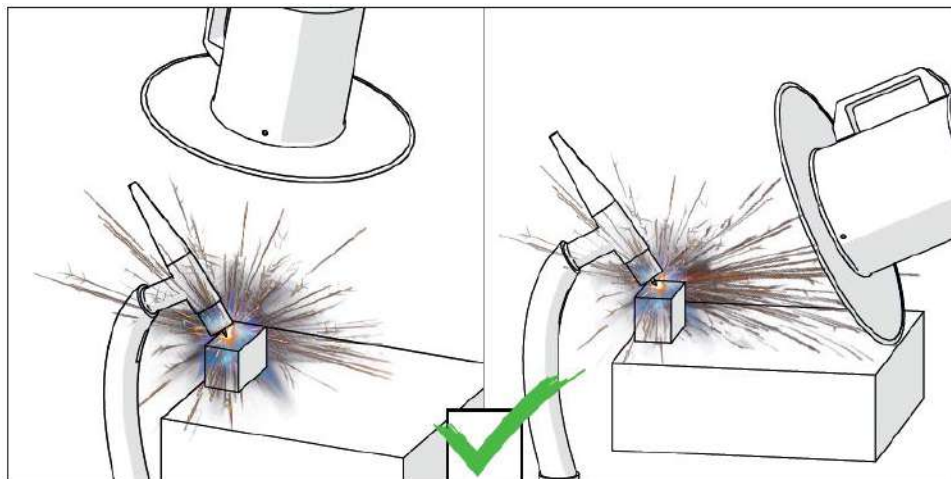

CAUTION !

RISK OF FIRE

When positioning the exhaust cap take into account the proper position to prevent inadequate ventilation and risk of ignition of the filter unit.

6.2.3. Timer mode parameters



The working and pause time regulation is possible through 2 comfortable knobs. During the working phase, the green LED turns on, while during the pause phase it occurs to the yellow LED. The timer has a TEST switch which it is able to check the correct working.

The pause time settings depend on the load of which the device is working.

<i>Recommended settings for timer mode</i>			
Load	Pause time	Work time	Description
Light	90 s	150 ms	A dust that is easy to clean off the filter cartridges such as dry stone dust or grinding dust
Normal	60 s	150 ms	Applications such as welding fume or light dust in heavy concentration
Heavy	30 s	150 ms	Typically metal cutting with laser or plasma or heavy welding

	CAUTION !
	Over cleaning the cartridges will result in higher emissions, shorter cartridge life and higher energy costs.

7. MALFUNCTIONS

	DANGER !
	<p>ELECTRIC SHOCK FROM HIGH VOLTAGES</p> <p><i>Severe injury and even death possible</i></p> <ul style="list-style-type: none"> • Any work on the electrical grid and on live components may be performed by an electrician • Follow the safety rules for working on electrical products • Shut down the product or any live components before working on them and secure them against reactivation • Do not clean electrical components with a water jet

	CAUTION !
	<p>TOXIC DUSTS</p> <p><i>Short-term impairment of the respiratory organs during inhalation</i></p> <ul style="list-style-type: none"> • Maintenance, cleaning, repair and emptying work may only be performed by expert personnel • Wear personal protective equipment • Regularly check the filter elements for clogging • Always complete all maintenance and upkeep work in a well-ventilated area • Do not blow out or whack the filter elements when they are disassembled • Dispose of used filter elements in air tight sealed disposal bags in accordance with applicable federal, state and regional regulations

7.1. Faults overview

7.1.1. Product

Fault	Possible solution
Insufficient airflow	<ul style="list-style-type: none"> - Adjust the flap on the top of the extraction arm - Check the tip of the extraction arm, possible damage - Check if the inlet or outlet of the filter unit is blocked - Clean the filter elements - Replace the filter elements
The device not work / start	<ul style="list-style-type: none"> - Check the power supply - Check phase loss - Check the electrical wiring
Leakage of impurities	<ul style="list-style-type: none"> - Check the filter elements, possible damage - Replace the filter elements

8. MAINTENANCE AND REPAIR

8.1. Maintenance schedule

The following table presents an overview of the maintenance tasks that need to be carried out regularly on the device. The intervals given are recommendations. Other intervals may become necessary for operational reasons, as the level of soiling on the filters depends on many factors, such as the machining process, materials, cooling lubricant, or crude gas exposure. That is why the maintenance tasks need to be carried out as specified.

Based on the observed results, the cleaning interval should be adapted step-by-step.

	The following task may be carried out only by persons that have at least the qualification of the maintenance and repair personnel.
---	---

	<p>CAUTION !</p> <p>If a defective unit is used, this compromises safety, functionality and availability. Never use defective unit!</p> <ul style="list-style-type: none">- Always use only technically correct device- Follow the maintenance schedule- Use only original spare parts- If you notice abnormal operation of the device, follow instructions or contact Tehno Filter Ltd.- Do not make changes on a device without Tehno Filter Ltd. permission
--	---

8.1.1. Visual inspection

Parts and components on the product that are damaged must be replaced immediately with new original parts.

Daily

- Check the entire product or parts thereof for damage
- Check if the product or parts thereof are dirty and clean if necessary, see Cleaning the product, Section. 8.1.7.
- Check for spills and deposits of media (e.g. trails of dust) on interfaces and outlet openings
- Check electrical cables for damage such as open cable insulation, crushing, visible wiring or heavy soiling
- Check the fill level of the collection container (regulation requires that the container be emptied if it is more than 2/3 full), see Emptying the collection bins, Section 8.1.6.
- Fan impeller noise / check drive motor startup (non-circular running, flapping, grinding, pounding)
 1. Switch the product off immediately if the noise indicates an unusual fault of the fan impeller
 2. Determine and eliminate the cause of the fault or initiate its removal by specialized personnel, e.g. have the drive motor and / or fan impeller replaced by specialized personnel

Weekly

- Check the inlet baffle for accumulations, clean as required

Annually

- Check to ensure the entire product is leak tight
- Have the fan checked by the manufacturer for proper fitting of the fixing screws and connections, cracks of the housing / sealing
- Check the compressed air tank: leaking of air condensate, compressed air connections on the product

8.1.2. Functional check

Monthly

- Check that all moving parts are firmly tightened
- Check the tightness of the hoses and connections
- Check the function of the operating and display elements
- Check the mains connection line for damage and replace damaged parts as necessary
- Check the protective devices (motor protection relay and grounding resistance) and have them adjusted by service personnel if necessary
- Tighten screw connections that are accessible from the outside

Annually

- Have the volume flow, vacuum and current consumption checked by Tehno Filter Ltd. Maintenance service

8.1.3. Check the filter elements

- Condition of the filter elements
- Damage and level of soiling
- Soiling in the interior between the filter elements and the discharge

8.1.4. Emptying the compressed air tank

	CAUTION !
	RISK OF HEARING DAMAGE <i>Release of compressed air pulses when filter elements are being cleaned</i> <ul style="list-style-type: none">• Wear hearing protection

After a longer period of operation, condensate collects in the compressed air tank. If this is not drained regularly it can lead to corrosion in the compressed air tank and insufficient cleaning of the filter cartridges.

For most cleaning, maintenance and repair work the compressed air tank must be emptied by manually cleaning the control unit if necessary; See chapter Manual cleaning.

1. Switch of extraction on control panel
2. Disconnect the compressed air supply
3. Switch off the product at the main switch and secure from re-operation
4. Open clean chamber.
5. Place a suitable container under the drain valve to collect the condensate
6. Open drain valve of the compressed air tank
7. When pressure gauge is displayed: "0", close the drain valve
 - the compressed air tank contains no air and condensate.
8. Re-connect the compressed air supply
9. Switch on the product again

8.1.5. Replacing filter cartridges

	CAUTION !
	TOXIC DUSTS <i>Short-term impairment of the respiratory organs during inhalation</i> <ul style="list-style-type: none">• Maintenance, cleaning, repair and emptying work may only be performed by expert personnel• Wear personal protective equipment• Regularly check the filter elements for clogging• Always complete all maintenance and upkeep work in a well-ventilated area• Do not blow out or whack the filter elements when they are disassembled• Dispose of used filter elements in air tight sealed disposal bags in accordance with applicable federal, state and regional regulations

After an extended period of operation, the filter elements gradually clog up due to the ingress of extremely fine dust into the pores. The cleaning device can no longer remove the penetrated dust. The filter elements must be replaced with new ones.

1. Switch off extraction on the control cabinet
2. Disconnect the compressed air supply
3. Empty the compressed air tank; use manual cleaning on the operating unit if necessary.
4. Wait at least 5 minutes until contaminants have settled in the collection bin.

5. Remove dust collection bin [A]. Check section 8.1.6. Emptying dust collection bin.
6. Remove hexagon nut and washer [B] from the threaded bar that is holding the filter cartridge [C]
7. Replace the filter cartridge with new original one by Tehno Filter Ltd. specification [C]
8. Make sure that filter cartridge top plate seal on the hole opening.

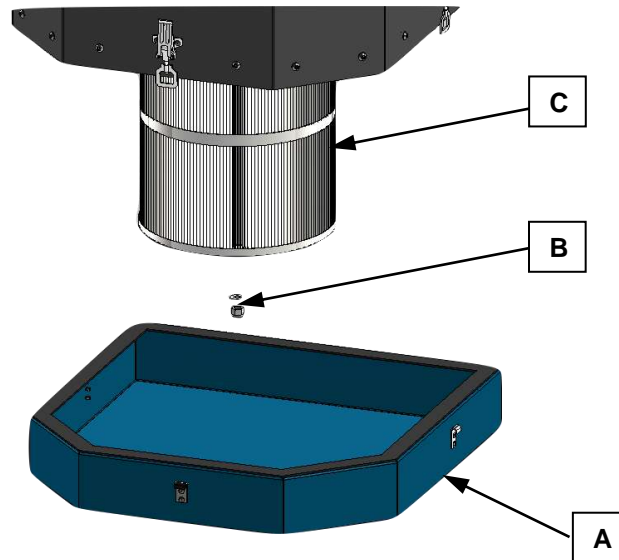

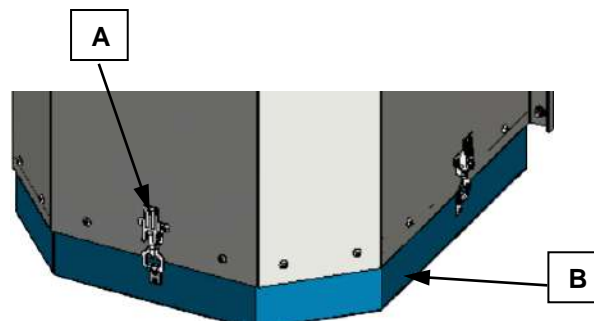

8.1.6. Emptying dust collection bin

1. Switch off extraction on the control cabinet
2. Disconnect the compressed air supply [A]
3. Empty the compressed air tank; use manual cleaning on the operating unit if necessary
4. Wait at least 5 minutes until contaminants have settled in the collection bin.
5. Remove hook clamps [A]
6. Remove and empty dust collection [B] bin per local regulative.



9. DECOMMISSIONING

9.1. Prepare for storage

	The following task may be carried out only by persons that have at least the qualification of the maintenance and repair personnel.
	The following task may be carried out only by persons that have at least the qualification of the transport personnel.

	CAUTION !
	TOXIC DUSTS <i>Short-term impairment of the respiratory organs during inhalation</i> <ul style="list-style-type: none">• Maintenance, cleaning, repair and emptying work may only be performed by expert personnel• Wear personal protective equipment• Regularly check the filter elements for clogging• Always complete all maintenance and upkeep work in a well-ventilated area• Do not blow out or whack the filter elements when they are disassembled• Dispose of used filter elements in air tight sealed disposal bags in accordance with applicable federal, state and regional regulations

Process as follows:

1. Clean filter elements.
2. Disconnect the product from the mains supply and secure it against re-activation.
3. Remove the filters and package them according to applicable federal, state and local regulations.
4. Empty the collection bins.
5. Clean the product inside and out, refer to Cleaning the product, chapter
6. Disconnect the compressed air supply.
7. Disconnect the cleaning controller cable from the control cabinet.
8. Disconnect the fan's drive motor cable from the control cabinet
9. Remove inlet and outlet ducts.
10. Securely fasten all loose hoses, piping and cables on the product
11. Use approved lifting gear to place the product onto a pallet and secure it with transport locks.

Product is prepared for relocation, storage or transport.

9.2. Storage conditions

Store the product in a dry room if it is not required for a longer period of time.

Storage temperature [°C]	+5 ≤ ≥ +25
Humidity [%]	Max. 70

Fan

To prevent “sticking” of the bearings in the drive motor of the fan, the impeller of the fan must be manually turned at intervals of approximately two weeks.

9.3. Disposal

	CAUTION !
	TOXIC DUSTS <i>Short-term impairment of the respiratory organs during inhalation</i> <ul style="list-style-type: none">• Maintenance, cleaning, repair and emptying work may only be performed by expert personnel• Wear personal protective equipment• Regularly check the filter elements for clogging• Always complete all maintenance and upkeep work in a well-ventilated area• Do not blow out or whack the filter elements when they are disassembled• Dispose of used filter elements in air tight sealed disposal bags in accordance with applicable federal, state and regional regulations

	NOTICE !
	CONTAMINATION TEHNO FILTER LTD. Cannot accept returns including individual parts due to the fact that the extraction system is contaminated with hazardous dust. Dispose of collected material and filter elements according to applicable federal, state and local regulations.

Process as follows:

1. Take the disposal carton out of the product and seal it tightly.
2. Remove the filter elements and package them air-tight.
3. Remove the detachable parts from the product.
4. Package the product and the detachable parts as specified by applicable federal, state and local regulations.
5. Dispose of all components according to applicable federal, state, and local regulations.

10. SPARE PARTS

	NOTICE !
	<p>PROPERTY DAMAGE</p> <ul style="list-style-type: none"> Store spare parts in the original packaging until used. Adhere to storage temperature

SPARE PARTS					
Model	Electric motor	Impeller	Filter cartridge	Valve	Timer
TFV – 1100	5050100085	400006254	5010201007	5030300093	5060100003
TFV – 1500	5050100176	200004456			
TFV - 2200	5050100234	400006055			

Note: when ordering spare parts always refer to the unit serial number from ID plate. For ID plate location check section 3.1.4.